



## Underground Tanks

*Trinity Containers Underground Tanks have the following features:*

- Trinity Containers' polyethylene underground lid for added strength, durability and ease of service
- Domes available in both 18" and 28" heights
- Vacuum pre-purged to save time, money and product
- Powder coated for a durable, long-lasting finish
- Trinity Containers uses all brass valves on our underground vessels
- Registered with the National Board
- Anode bolt for fast, secure connection of lead wires
- Dual lifting lugs on 500s & 1000s for easier installation
- Stainless steel duplicate nameplate cabled to the riser pipe

\* Applicable federal, state or local regulations may contain specific requirements for protective coatings and cathodic protection. The purchaser and installer are responsible for compliance with all federal, state, local and NFPA industry regulations. Cathodic protection is required and coating must be continuous and uninterrupted and must comply with any local and national code.



*Trinity Containers introduced the single piece, polyethylene underground dome to provide additional workspace and greater strength for a longer life and less maintenance.*

# TRINITY CONTAINERS, LLC UNDERGROUND TANKS

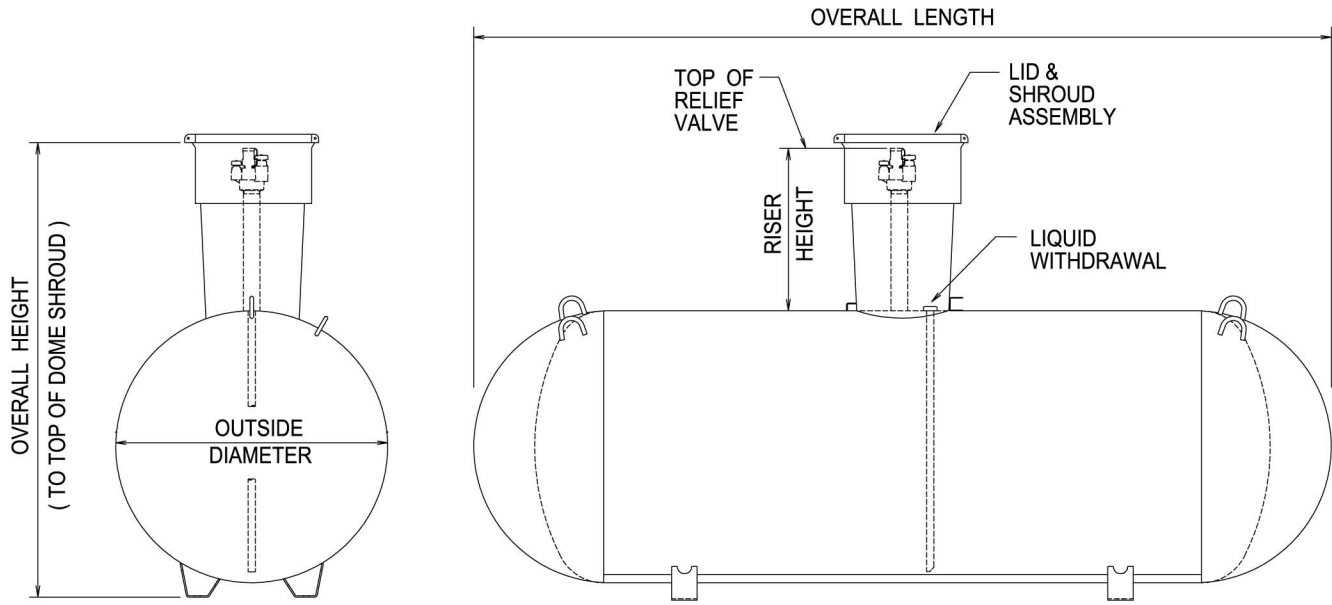

## General Specifications

Conforms to the last edition and addenda of the ASME, Section VIII, Division 1. Complies with NFPA 58. The 28" Riser tank conforms to specifications set forth by the Railroad Commission of Texas.

Rated at 250 psig from -20° F. to 125° F. All tanks may be be evacuated to a full (14.7 psi) vacuum.

Vessel finish: Coated with TGIC red powder.

Applicable federal, state or local regulations may contain specific requirements for protective coatings and cathodic protection. The purchaser and installer are responsible for compliance with such federal, state, or local regulations.

<b>UNDERGROUND VESSEL DIMENSIONAL INFORMATION</b>						
All vessels dimensions are approximate						
WATER CAPACITY	OUTSIDE DIAMETER	HEAD TYPE	OVERALL LENGTH	OVERALL HEIGHT Riser Height 28"		WEIGHT
120 wg. 454.2 L	24" 609.6 mm	Ellip	5' - 5 7/8" 1673.2 mm		5' - 0 3/8" 1533.5mm	252 lbs. 114.3 kg.
250 wg. 946.3 L	31.5" 800.1 mm	Hemi	7' - 2 1/2" 2197.1 mm		5' - 7 3/8" 1711.3 mm	472 lbs. 214.1 kg.
320 wg. 1211.2 L	31.5" 800.1 mm	Hemi	8' - 11 3/4" 2736.9 mm		5' - 7 3/8" 1711.3 mm	588 lbs. 266.7 kg.
500 wg. 1892.5 L	37.42" 950.5 mm	Hemi	9' - 10" 2997.2 mm		6' - 1 7/8" 1863.7 mm	921 lbs. 417.8 kg
1000 wg. 3785.0 L	40.96" 1040.4 mm	Hemi	15' - 10 7/8" 4848.2 mm		6' - 5 3/8" 1965.3mm	1731 lbs. 785.2 kg
1465 wg. 5545.0 L	46.614" 1184 mm	Ellip	17' - 7 1/4" 5365.8 mm		6' - 11 1/16" 2109.8 mm	2745 lbs. 1245 kg
2000 wg. 7570.0 L	46.614" 1184 mm	Ellip	23' - 9 3/8" 7248.5 mm		6' - 11 5/16" 2065.3 mm	3685 lbs. 1671.4 kg